

# ES-OPUSDC FANS

Compact in-line fan offering high performance with low noise.

Suited to ceiling voids, the ES-OPUSDC has easy commissioning for a simple, guaranteed ventilation solution.

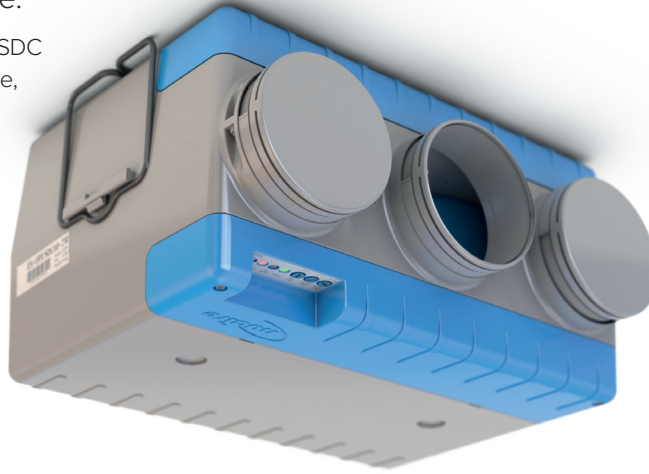

## CODING ES-OPUSDC40-M

ES - OPUSDC 40 - 2 M  
 1 2 3 4 5 6

1. Ecosmart control
2. Opus range
3. DC = direct current, low watt
4. 40 = unit size
5. 2 = Twin model  
No reference = Single fan
6. M = Duct mounted



### VERY QUIET OPERATION

Units offer high performance with low noise levels.



### GUARANTEED VENTILATION

Twin fans allow for automatic changeover to standby fan in event of fan failure.



### QUICK AND EASY INSTALL

Quick release bracket with no need for additional fixings.



### SIMPLE TO COMMISSION

Integral control facilities enables the duty to be precisely set without the need for additional controls.



### SIMPLE CONTROLS

A choice of 'on-board' and 'remote' control options available, including Ecosmart energy efficient controls.

## PERFORMANCE & TECHNICAL INFORMATION

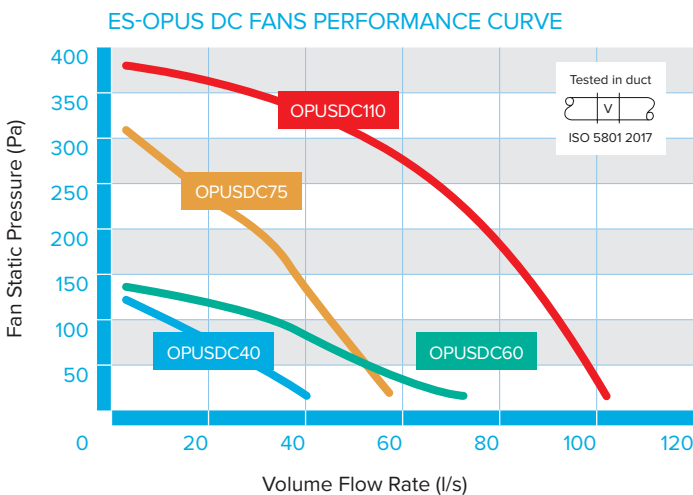

Bottom View

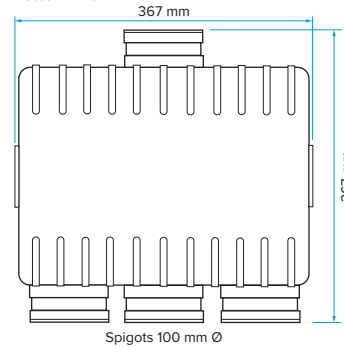

Side View

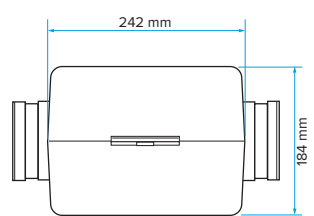

### DIMENSIONS AND WEIGHT

Weight 3Kg.

### TECHNICAL DATA

CODE	PHASE	FLC (A)	dB(A) @3M
ES-OPUSDC40	1	0.14	29
ES-OPUSDC60	1	0.32	34
ES-OPUSDC110	1	0.46	37

## ES-OPUSDC

### CONSULTANT SPECIFICATION

#### OPERATION

The extract fans shall be as indicated on the drawings and shall be in accordance with the fan schedule in the specification. The vitiated air shall be extracted from each area via ductwork as shown. All necessary ductwork fittings and ancillaries shall be allowed for by the mechanical sub-contractor. The extract fan shall automatically vary its speed as it receives signals from one of the interconnected sensors sited in the rooms being ventilated. When the signal is received the fan shall have the ability to increase speed gradually until the required level is achieved or it will work on a trickle and boost principle i.e. increase ventilation rate from the continuous background rate to the design maximum in one step.

#### FAN SPECIFICATION

The fans shall have low energy, high efficiency DC fan/motor assembly with sealed for life bearings, mounted within an acoustically lined, 100% recyclable plastic case, ensuring a very efficient quiet solution. It shall have noise levels and power requirements as detailed in the specification and in accordance with the manufacturer's details.

The unit shall incorporate a quick release mounting bracket. The bracket shall enable the unit to be mounted horizontally or vertically, enabling the unit to be removed without the aid of specialist tools. The depth of the unit shall not be greater than 190mm (including mounting bracket). The unit shall be constructed with one removable panel allowing quick and easy access to the electrical connections.

For commissioning purposes the unit shall have a miniature control panel mounted in its fascia facilitating high and low speed adjustment (trickle and boost) together with run on timer (1-60minutes) and shall be accessible without the need of removing any access panels or the unit itself. Any adjustments shall be quickly and easily achieved with a standard screwdriver. The control panel shall also have status indication lamps on the underside of the unit.

Run and standby versions shall have auto changeover and duty share as standard, the fan shall changeover every twelve hours of run time to maximise the unit's effective life span.

Three number 100 diameter circular spigots on the system side of the unit are available to allow the ventilation of a number of rooms or points from a single unit. Two of the spigots have blanks fitted which are easily removed to facilitate the interconnection of ductwork.

#### CONTROL SPECIFICATION

The fan unit shall have the following functions integrally mounted within the fan unit on a purpose made PCB, all such components pre-wired and factory fitted by the manufacturer:

- Integrated infinitely variable speed control.
- Integral background ventilation commissioning facility.
- Integral boost ventilation commissioning facility.
- Auto changeover and duty share (twin fan unit only).

- Integral adjustable run on timer.
- Integral S/L terminal for boost trigger from remote switch, e.g. light switch.
- 4no. IDC sockets for interconnection of Ecosmart fans or low voltage sensors using pre-plugged 4-core low voltage cable. Multiple fans can be interconnected and run from one or more sensor or controller.
- Remote volt free run and fail status indication.
- Fascia mounted fan failure, system status indication as follows:
  - Fan 1 status.
  - Fan 2 status.
  - Power to fan.
  - System standby.
  - 5 year warranty.

Fan shall be the ES-OPUSDC type unit as manufactured by Nuair.

The user control and low voltage sensors are supplied complete with a 10m length of low voltage, pre-plugged cable to facilitate their interconnection (other length of cables available).

The manufacturer's recommendations should be observed at all times.